



Power Riemen

Rua José Neves, 381 – sala 03
Cep: 04650-141 - São Paulo - SP
Tel.:++55 **11-3227-7311 / 3487-1256
Tel/Fax.:++55 **11 – 3229-0695
e-mail: power.riemen@gmail.com / vendas@powerriemen.com.br
www.powerriemen.com.br

Para dados técnicos favor acessar o site.



Aplicamos e oferecemos correias com os revestimentos acima, entre em contato e faça uma consulta.

Rua José Neves, 381 – sala 03
Cep: 04650-141 - São Paulo - SP
Tel.:++55 **11-3227-7311 / 3487-1256
Tel/Fax.:++55 **11 – 3229-0695
e-mail: power.riemen@gmail.com / vendas@powerriemen.com.br
www.powerriemen.com.br

Power Riemen

Cinta de PU com fio de aço

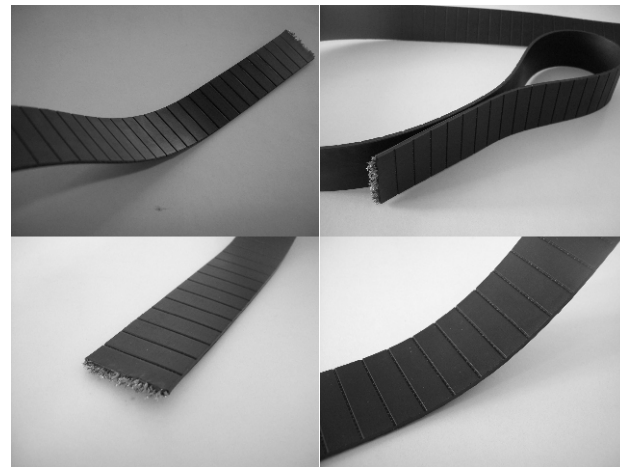

Correia com 2mm de espessura de PU com fio de aço,
sendo a aplicação para aparelho de academia, elevadores e etc..

Polias



Oferecemos polias de todos os passos em alumínio ou ferro
entre em contato e faça uma consulta.

A Power Riemen é fornecedora de componentes
e acessórios industriais.

Nossa missão é atender os clientes cada vez mais rápido e barato.

Nos consulte e perceba que somos a alternativa para quem quer
comprar mais em conta.

Power Riemen

Fornecemos correias sincronizadoras de poliuretano e borracha,
duplo dente, aberta, emendada, sem emenda e correias em v.

Temos correias nos passos: ATP10, ATP15, AT3, AT5 AT10 At20,

T2,5, T5, T10, T20, BAT, BATK10, SFAT10, SFAT15, SFAT20,

ATK5, ATK10, TK5, TK10, MXL, M, XL, L, XH, XXH, ATN10,

3M, 5M, 8M, 14M, 20M,

Flat belt correia para academia (cinta / fita)

Aplicamos revestimentos e taliscas nas correias.

Trabalhamos com as melhores marcas do mercado.

Rua José Neves, 381 – sala 03 Cep: 04650-141 - São Paulo - SP
Tel.:++55 **11-3227-7311 / 3487-1256Tel/Fax.:++55 **11 – 3229-0695
e-mail: power.riemen@gmail.com / vendas@powerriemen.com.br
www.powerriemen.com.br

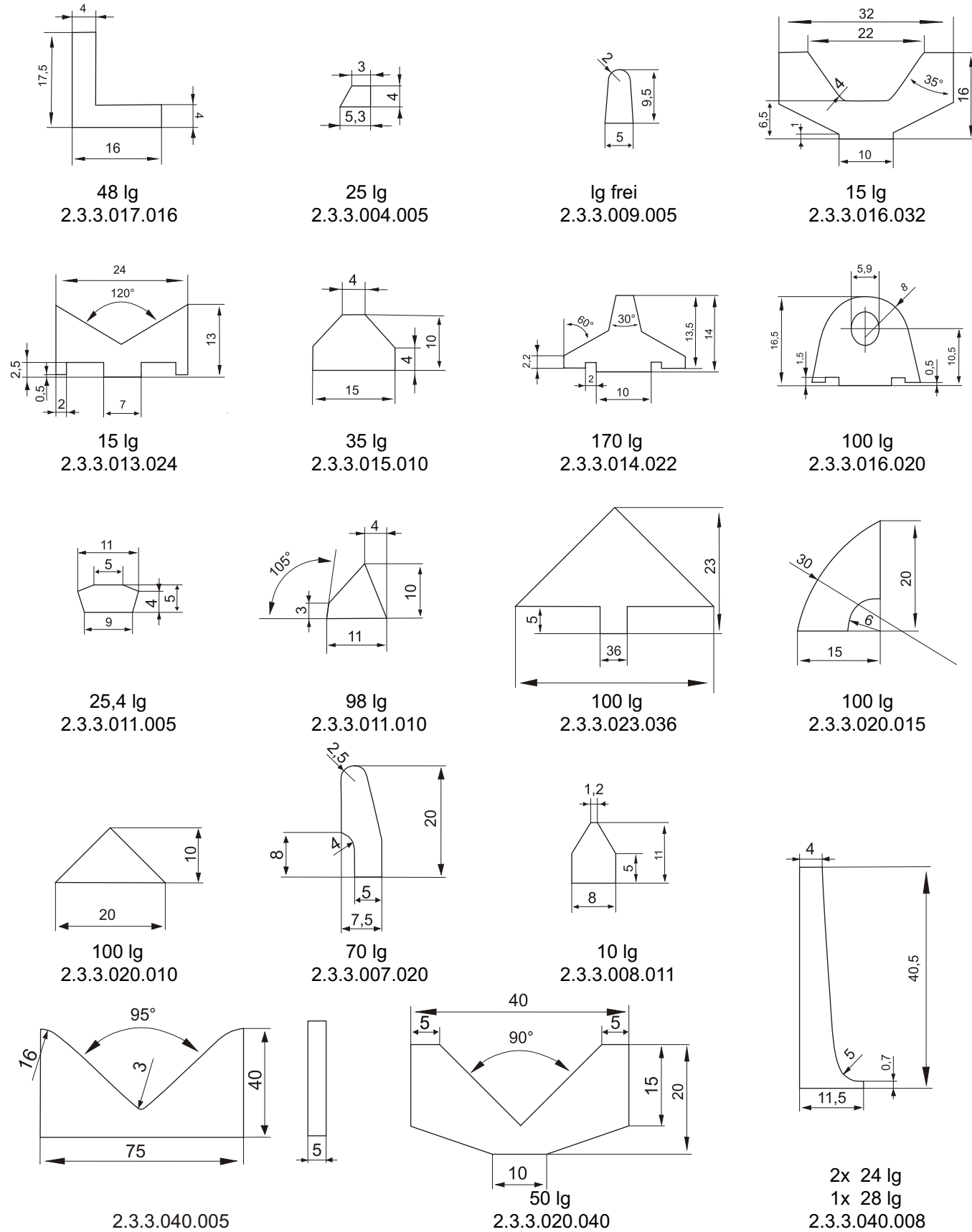

ATP 10

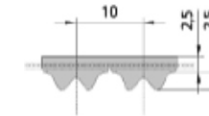

Passo	Comprimento	Nr. de dentes
ATP 10	630	63
ATP 10	660	66
ATP 10	700	70
ATP 10	780	78
ATP 10	840	84
ATP 10	890	89
ATP 10	920	92
ATP 10	1010	101
ATP 10	1080	108
ATP 10	1150	115
ATP 10	1280	128
ATP 10	1400	140
ATP 10	1650	165
ATP 10	1760	176
ATP 10	1800	180

ATP 15

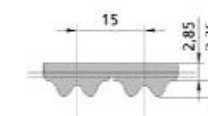

Passo	Comprimento	Nr. de dentes
ATP 15	990**	66
ATP 15	1125	75
ATP 15	1185	79
ATP 15	1260	84
ATP 15	1395**	93
ATP 15	1560	104

BAT 10

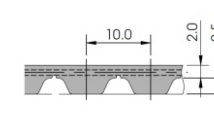

Passo	Comprimento	Nr. de dentes
BAT 10	1100	110
BAT 10	1150	115
BAT 10	1210	121
BAT 10	1240	124
BAT 10	1250	125
BAT 10	1320	132
BAT 10	1400	140
BAT 10	1500	150
BAT 10	1600	160
BAT 10	1700	170
BAT 10	1800	180
BAT 10	1900	190
BAT 10	2000	200
BAT 10	2240	224
BAT 10	2500	250
BAT 10	2800	280
BAT 10	3000	300
BAT 10	3550	355
BAT 10	4000	400
BAT 10	4500	450

BATK10

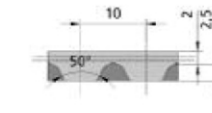

Passo	Comprimento	Nr. de dentes
BAT 10	5000	500
BAT 10	5600	560
BAT 10	6000	600
BAT 10	6700	670
BAT 10	7100	710
BAT 10	7500	750
BAT 10	20000	2000

Passo	Comprimento	Nr. de dentes
BATK10	1100	110
BATK10	1150	115
BATK10	1210	121
BATK10	1240	124
BATK10	1250	125
BATK10	1320	132
BATK10	1400	140
BATK10	1500	150
BATK10	1600	160
BATK10	1700	170
BATK10	1800	180
BATK10	1900	190
BATK10	2000	200
BATK10	2240	224
BATK10	2500	250
BATK10	2800	280
BATK10	3000	300
BATK10	3550	355
BATK10	4000	400
BATK10	4500	450

Passo	Comprimento	Nr. de dentes
BATK10	5000	500
BATK10	5600	560
BATK10	6000	600
BATK10	6700	670
BATK10	7100	710
BATK10	7500	750
BATK10	20000	2000

AT3

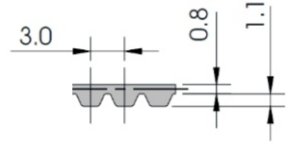

Passo	Comprimento	Nr. de dentes
AT 3	150	50
AT 3	201	67
AT 3	252	84
AT 3	267	89
AT 3	270	90
AT 3	300	100
AT 3	351	117
AT 3	399	133
AT 3	417	139
AT 3	450	150
AT 3	501	167
AT 3	549	183
AT 3	600	200
AT 3	639	213
AT 3	648 FN24	216
AT 3	816 FA	272
AT 3	816	272
AT 3	900	300

AT5

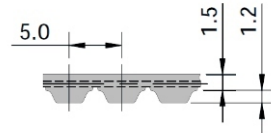

Passo	Comprimento	Nr. de dentes
AT 5	225	45
AT 5	255	51
AT 5	260	52
AT 5	280	56
AT 5	300	60
AT 5	330	66
AT 5	340	68
AT 5	375	75
AT 5	390	78
AT 5	420	84
AT 5	450	90
AT 5	455	91
AT 5	480	96
AT 5	500	100
AT 5	525	105
AT 5	545	109
AT 5	600	120
AT 5	610	122
AT 5	620	124
AT 5	630	126

AT10

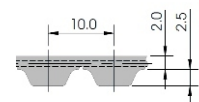

Passo	Comprimento	Nr. de dentes
AT 10	500	50
AT 10	560	56
AT 10	580	58
AT 10	600	60
AT 10	610	61
AT 10	660	66
AT 10	700	70
AT 10	730	73
AT 10	780	78
AT 10	800	80
AT 10	840	84
AT 10	890	89
AT 10	920	92
AT 10	960	96
AT 10	980	98
AT 10	1000	100
AT 10	1010	101
AT 10	1050	105
AT 10	1080	108
AT 10	1100	110

AT20

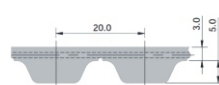

Passo	Comprimento	Nr. de dentes
AT 20	1000	50
AT 20	1100	55
AT 20	1200	60
AT 20	1260	63
AT 20	1500	75
AT 20	1600	80
AT 20	1700	85
AT 20	1760	88
AT 20	1800	90
AT 20	1900	95
AT 20	1960	98

